



# Standard Test Method for Measuring Rubber Deterioration—Cut Growth Using Ross Flexing Apparatus<sup>1</sup>

This standard is issued under the fixed designation D 1052; the number immediately following the designation indicates the year of original adoption or, in the case of revision, the year of last revision. A number in parentheses indicates the year of last reapproval. A superscript epsilon ( $\epsilon$ ) indicates an editorial change since the last revision or reapproval.

*This standard has been approved for use by agencies of the Department of Defense.*

<sup>€1</sup> NOTE—Sections 10 and 2 were editorially updated in November 1999.

## 1. Scope

1.1 This test method describes a test for measuring the cut growth in rubber vulcanizates subjected to repeated bend flexing.

1.2 The values stated in SI units are to be regarded as the standard.

1.3 *This standard does not purport to address all of the safety concerns, if any, associated with its use. It is the responsibility of the user of this standard to establish appropriate safety and health practices and determine the applicability of regulatory limitations prior to use.*

## 2. Referenced Documents

### 2.1 ASTM Standards:

D 573 Test Method for Rubber—Deterioration in an Air Oven<sup>2</sup>

D 1349 Practice for Rubber—Standard Temperatures for Testing<sup>2</sup>

D 3183 Practice for Rubber—Preparation of Pieces for Test Purposes from Products<sup>2</sup>

D 3767 Practice for Rubber—Measurement of Dimensions<sup>2</sup>

D 4483 Practice for Determining Precision for Test Method Standards in the Rubber and Carbon Black Industries<sup>2</sup>

## 3. Summary of Test Method

3.1 A pierced strip test specimen is bent freely over a rod to a 90° angle and the cut length is measured at frequent intervals, to determine the cut growth rate. The cut is initiated by a special shaped piercing tool.

## 4. Significance and Use

4.1 The test gives an estimate of the ability of rubber vulcanizates to resist crack growth of a pierced specimen when subjected to bend flexing.

4.2 No exact correlation between these test results and

service is implied due to the varied nature of service conditions.

## 5. Apparatus

5.1 *Ross Flexing Machine*—The machine, as illustrated in Fig. 1 and Fig. 2, allows one end of the test specimen to be clamped firmly to a holder arm while the pierced end is placed between two rollers that must permit a free bending movement of the test specimen during the test. During each cycle, the pierced area of the test specimen is bent freely over a 10-mm (0.4 in.) diameter rod through a 90° angle. The machine shall operate at  $1.7 \pm 0.08$  Hz ( $100 \pm 5$  cpm).

5.2 *Piercing Tool and Holder*, as shown in Fig. 3.

5.3 *Measuring Scale* of suitable length, graduated in millimetres (or 0.01 in.) for measuring the length of cut growth.

5.4 *Micrometer*, to measure the thickness of the test specimen as specified in Practice D 3767.

## 6. Test Specimens

6.1 At least two, preferably three, test specimens of each sample shall be tested simultaneously.

6.1.1 The test specimens shall be  $25 \pm 1$  mm ( $1.00 \pm 0.05$  in.) in width, a minimum of 152 mm (6.0 in.) in length, and  $6.35 \pm 0.03$  mm ( $0.25 \pm 0.01$  in.) in thickness, and shall be cut from a vulcanized sheet  $6.35 \pm 0.03$  mm ( $0.25 \pm 0.01$  in.) in thickness and of suitable dimensions or from finished articles by cutting and buffing. If obtained from a manufactured article, the piece of rubber shall be free of surface roughness, fabric layers, etc., in accordance with the procedure described in Practice D 3183.

6.1.2 Unless otherwise specified, the test specimens shall be prepared so that the longitudinal dimension is parallel with the direction of the milling grain.

NOTE 1—When specimens of high hardness are being tested, thicknesses other than standard may be used as agreed upon between the supplier and the consumer.

6.2 Unless otherwise specified, the test specimens shall be aged for 24 h at 100°C (212°F) in accordance with Test Method D 573 and then allowed to remain in the Standard Laboratory Atmosphere in accordance with Practice D 1349, having a

<sup>1</sup> This test method is under the jurisdiction of ASTM Committee D-11 on Rubber and is the direct responsibility of Subcommittee D11.15 on Degradation Tests.

Current edition approved March 29, 1985. Published May 1985. Originally published as D 1052 – 49. Last previous edition D 1052 – 55 (1976).

<sup>2</sup> *Annual Book of ASTM Standards*, Vol 09.01.

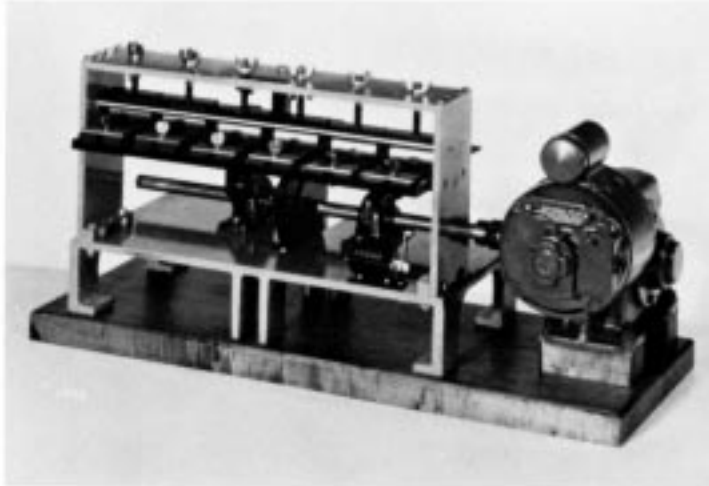
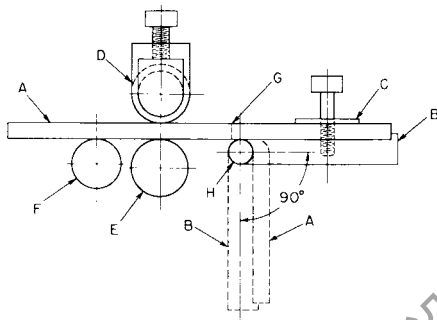

FIG. 1 Ross Flexing Machine



- A—Test Specimen.
- B—Holder arm.
- C—Holder arm adjustment.
- D—Adjustable top roller.
- E—Fixed lower roller.
- F—Supporting fixed lower roller.
- G—Pierced section.
- H—10 mm (0.375 in.) diameter rod over which specimen bends freely through a 90° angle.

FIG. 2 Schematic Diagram of Ross Flexing Machine

relative humidity of  $50 \pm 5\%$  and a temperature of  $23 \pm 2^\circ\text{C}$  ( $73 \pm 3.6^\circ\text{F}$ ), for a period of 16 to 96 h.

6.3 The test specimens shall be pierced by use of the piercing tool. The piercing tool shall be adjusted in the holder with the cutting edge projecting  $7.0 \pm 0.3$  mm ( $0.275 \pm 0.010$  in.) from the base of the holder so that it will pierce completely through the test specimens when tapped. Before piercing each test specimen, the piercing tool shall be lubricated with a soap solution that will not react with the rubber. The cut made by the piercing tool shall be parallel to the width of the test specimen, at a right angle to and across the longitudinal center line of the specimen at a  $62 \pm 2$  mm ( $2.44 \pm 0.05$  in.) distance from the clamped end.

## 7. Test Temperature

7.1 Unless otherwise specified, the test temperature shall be  $23 \pm 2^\circ\text{C}$  ( $73 \pm 3.6^\circ\text{F}$ ).

## 8. Procedure

8.1 Measure and record the median thickness of the test

specimen taken at three points across the width at the point of the cut.

8.2 With the holder arm of the flexing machine in a horizontal position, clamp side by side the test specimens of the same making sure that the cuts are at the center point of the arc of the rod.

8.3 Lower the adjustable top rollers until they just touch the test specimen and lock in this position by means of the wing nuts, permitting free travel of the test specimens between the rollers during the bending movement. The position of the test specimen is shown in Fig. 2.

NOTE 2—It is recommended that the test specimens be distributed evenly on both sides of the apparatus if only a few are tested.

8.4 Start the machine and record the number of cycles by the use of a counter. Make frequent observations, recording the number of cycles and the increase in cut length measured to the nearest 0.5 mm for the purpose of determining the rate of increase in cut length. When observing cut growth, the holder arm shall be at an angle approximately  $45^\circ$  from the vertical. The test shall be continued until the cut length has increased 500%, that is, until the combined length of the cut and crack has increased to a total of 15.0 mm (0.60 in.) or when 250 kilocycles has been reached with slow cracking samples.

8.5 In some cases the cut growth is not in a straight line as a continuation of the cut made by the piercing tool, and “star-shaped” cracking may develop. In this event, the cut growth shall be measured as the length of the longest continuous crack, regardless of its direction.

8.6 When it is necessary to stop operation of the machine temporarily, the holder arm shall be in a horizontal position, so that the test specimens remain horizontal while not being flexed.

## 9. Report

9.1 The report shall include the following:

- 9.1.1 Sample identification,
- 9.1.2 Specimen medium thickness,
- 9.1.3 Test temperature if other than  $23 \pm 2^\circ\text{C}$  ( $73 \pm 3.6^\circ\text{F}$ ),

and

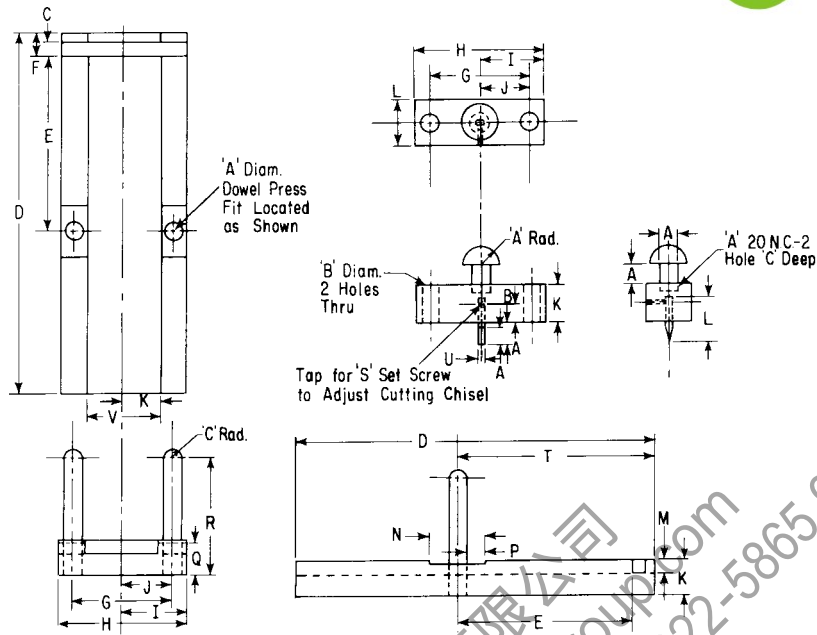

	mm	in.
A	6.4 ± 0.01	0.250 ± 0.005
B	7.0 ± 0.01	0.275 ± 0.005
C	3 ± 0.01	0.125 ± 0.005
D	127 ± 0.06	5 ± 0.025
E	62 ± 0.03	2.438 ± 0.015
F	8 ± 0.01	0.313 ± 0.005
G	35 ± 0.02	1.375 ± 0.010
H	45 ± 0.02	1.250 ± 0.010
I	22 ± 0.02	0.875 ± 0.008
J	17 ± 0.02	0.688 ± 0.008
K	12 ± 0.02	0.500 ± 0.008
L	16 ± 0.02	0.625 ± 0.008
M	5 ± 0.01	0.125 ± 0.005
N	4 ± 0.01	0.250 ± 0.005
P	10 ± 0.01	0.375 ± 0.005
Q	11 ± 0.01	0.438 ± 0.005
R	41 ± 0.02	1.625 ± 0.010
S	6 to 32 screws	
T	70 ± 0.03	2.750 ± 0.015
U	2.5 ± 0.01	0.10 ± 0.005
V	25 ± 0.02	1 ± 0.010

FIG. 3 Piercing Tool and Holder

9.1.4 The average number of cycles for each 100 % increase in cut growth above the initial pierce of 2.5 mm (0.10 in.) of the tested specimens, up to and including 500 %, where possible.

the form specified by Practice D 4483.

## 10. Precision and Bias

10.1 The precision and bias statements will be prepared in

*The American Society for Testing and Materials takes no position respecting the validity of any patent rights asserted in connection with any item mentioned in this standard. Users of this standard are expressly advised that determination of the validity of any such patent rights, and the risk of infringement of such rights, are entirely their own responsibility.*

*This standard is subject to revision at any time by the responsible technical committee and must be reviewed every five years and if not revised, either reapproved or withdrawn. Your comments are invited either for revision of this standard or for additional standards and should be addressed to ASTM Headquarters. Your comments will receive careful consideration at a meeting of the responsible technical committee, which you may attend. If you feel that your comments have not received a fair hearing you should make your views known to the ASTM Committee on Standards, at the address shown below.*

*This standard is copyrighted by ASTM, 100 Barr Harbor Drive, PO Box C700, West Conshohocken, PA 19428-2959, United States. Individual reprints (single or multiple copies) of this standard may be obtained by contacting ASTM at the above address or at 610-832-9585 (phone), 610-832-9555 (fax), or service@astm.org (e-mail); or through the ASTM website (www.astm.org).*

苏瑞电子设备（天津）有限公司  
全球唯一官方网站：[www.surui.com](http://www.surui.com)  
24小时销售热线：+86 022-5865.1258/ +86 022-5865.9889